

MODULO

MY LIFE STYLE, MY DESIGN



Z-Pattern Installation Guide

MODULO

MY LIFE STYLE, MY DESIGN

Please read entire instruction manual thoroughly prior to the installation of your Modulo Z-Pattern Product. The details included in this manual are guidelines only. Modulo is not responsible for damage to your structure, substrate, or any damage caused by improper installation.

If you have any questions please contact our technical department: support@compstone.com or you may visit moduloamerica.com for tips and installation recommendations.



moduloamerica.com

Z-Pattern Installation Guide

Contents

Introduction and Overview	4
Required Materials and Product Overview	5
Range of Use and Preparing the Surface	6
Installation: Using Corner Pieces	7
Installation	8
Installation (Continued)	9
Maintenance and Contractual Warranty	10

Introduction and Overview



Getting Started

Thank you for your purchase of our Modulo Z-Pattern Product. We know that you will enjoy these products, and along the way, should you have any questions or concerns you may reach us at support@compstone.com Modulo products can be used in a variety of applications and can be installed literally anywhere you want a custom look. Interiors, fireplaces, basements, kitchens etc. We have developed this guide help you through the installation of your new stone.

Before Installing:

The manufacturer does not provide any installation services, other than the guidelines contained in this document.

The surface must be perfectly straight, solid with no cracks, and free of dust. If needed, sandpaper can be used to remove all traces of previous materials. Clean surface with a damp sponge.

⚠ Note: Stack Stone products are not returnable unless they have been crushed. Cracked stones and broken stones can still be installed.

Helpful Tips:

Always stagger your joints, this will break up the pattern and make the installation look more natural. You may need to use a file to fine tune the fit.

As there are a variety of shades in each box, it is recommended that before beginning the installation you mix the products from several boxes to ensure a harmony of colors.

Save any extra material so that you have some in case stone gets damaged in the future.

⚠ It is the responsibility of the installer to ensure that the products are installed in accordance with these instructions and any applicable building codes.

Required Materials and Product Overview

Required Materials:

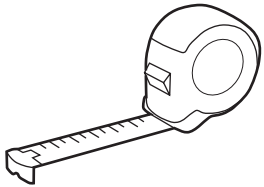

Tape Measure



Pencil



Level



File

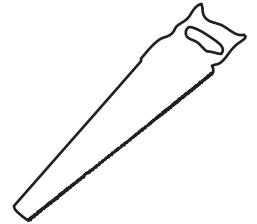

Drywall Saw



Sealer



**9 oz. Liquid Nails
LN-2000 FUZE*IT®
Adhesive**
(covers approx. 25 sq.
feet of stone)

Product Overview:

Z-Pattern Product Front

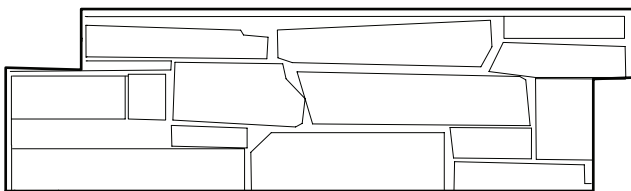

Z-Pattern Product Back

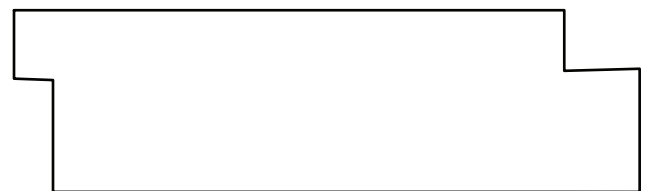

Range Of Use and Preparing The Surface

Range of use:

Modulo Interior Products are intended for indoor installation, where the temperature is above 60°F and 100°F. Installing the Modulo Interior Products is not recommended in spaces exposed to a high humidity factor such as saunas, steam baths, or bathrooms.

Warning: Avoid frost and water.

Warning: Do not place the decorative stones on the ground, ceiling, or mobile surfaces.

Recommendation: We recommend that you purchase at once the entire quantity (adding 5% waste) required for your work. We recommend that you mix the stone from multiple boxes to achieve a harmony of tones.

Measure Job Size: Width x Height = Square Feet needed (+ 5% waste)

Preparing the Surface:

Accepted Surfaces

Modulo Interior Products can be used on the following surfaces:

- Drywall
- Tile
- Aluminum
- Plastic
- Glass
- Metal
- Ceramic
- Granite
- Marble
- Rubber
- Laminate
- OSB
- Cement Walls
- Fiberboard
- Wood

Installation: Using Corner Pieces

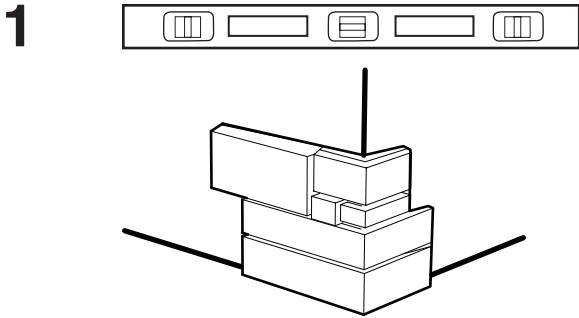

Starting on the bottom corner, place the stone in its future position. Use a level to ensure that it will be placed straight. You may have to shave the stone or use caulk to fill in a gap if a gap is present to make sure it is level.

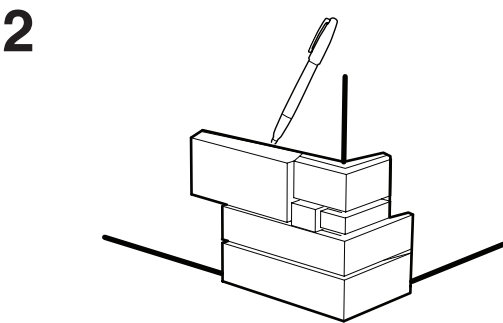

Draw a line to mark its position.

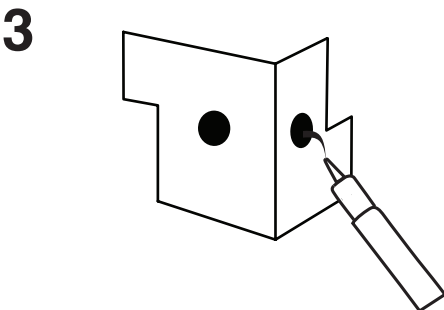

Apply 2 dots (size of a quarter) with Liquid Nails LN-2000 FUZE*IT® Adhesive to the back of the stone.

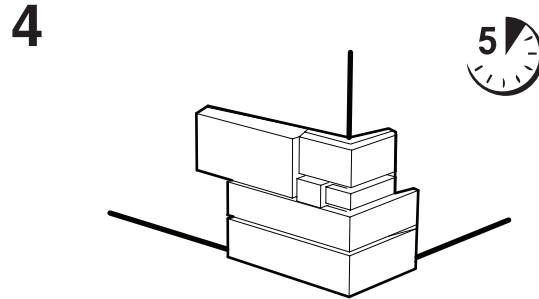

Apply the stone to the line drawn on the wall by pressing firmly and holding it in position for five seconds. This ensures that the stone adheres completely to the surface.

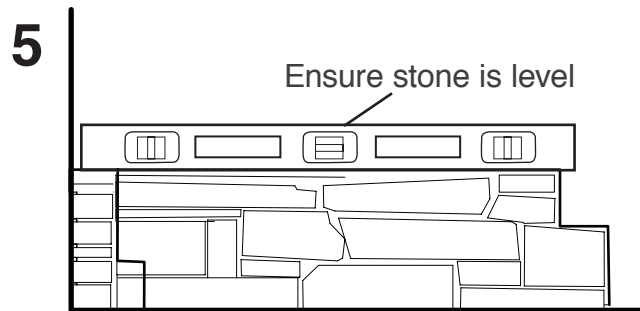

Position the next stone using a level and repeating the previous process. You may want to use a file on the edges to ensure a level and tight fit. Clean off burrs if necessary. (No grouting - Dry stack style).

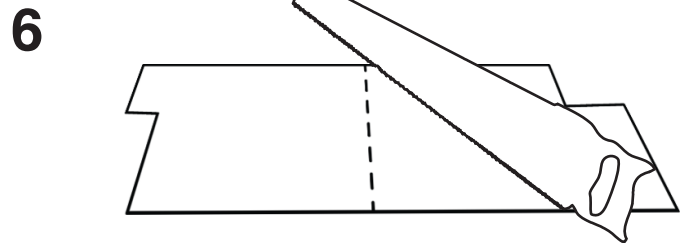

Applying the seam offset to the first row will ensure a more natural look. In order to do this, place the stone in a place suitable for cutting, draw a straight line, and cut the stone using a drywall saw.

Note: Illustrations not to scale

Installation

1

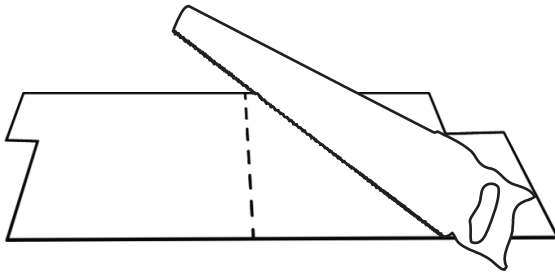

Cut the first piece of stone in half so it will line up flush with the wall. In order to do this, place the stone in a place suitable for cutting, draw a line, and cut the stone using a drywall saw.

4

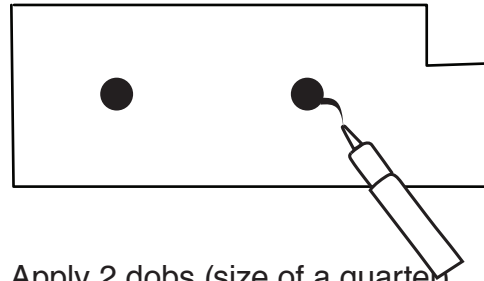

Apply 2 dots (size of a quarter) with Liquid Nails LN-2000 FUZE*IT® Adhesive to the back of the stone.

2

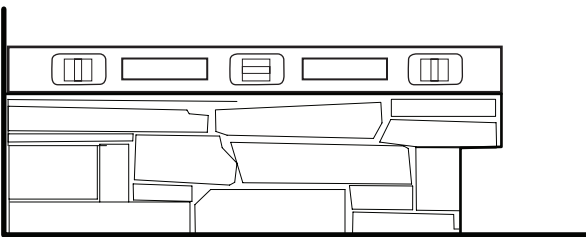

Starting on the bottom left, place the stone in its future position. Use a level to ensure that it will be placed straight. You may have to shave the stone or use caulk to fill in a gap if a gap is present to make sure it is level.

5

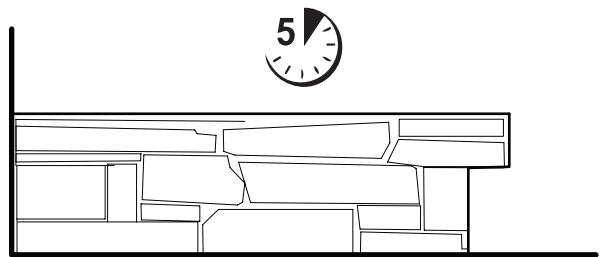

Apply the stone to the line drawn on the wall by pressing firmly and holding it in position for five seconds. This ensures that the stone adheres completely to the surface.

3

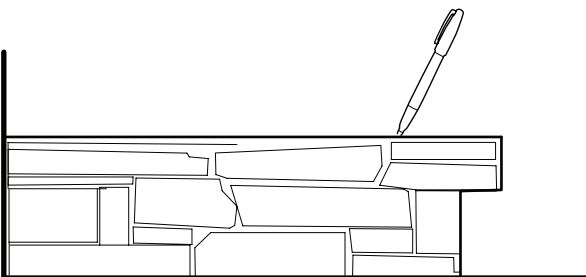

Draw a line to mark its position.

6

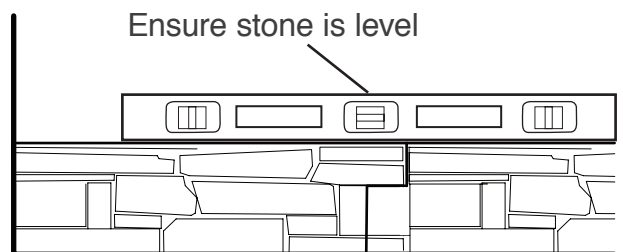

Position the next stone using a level and repeating the previous process. You may want to use a file on the edges to ensure a level and tight fit. Clean off burrs if necessary. (No grouting - Dry stack style).

Note: Illustrations not to scale

Installation (Continued)

7

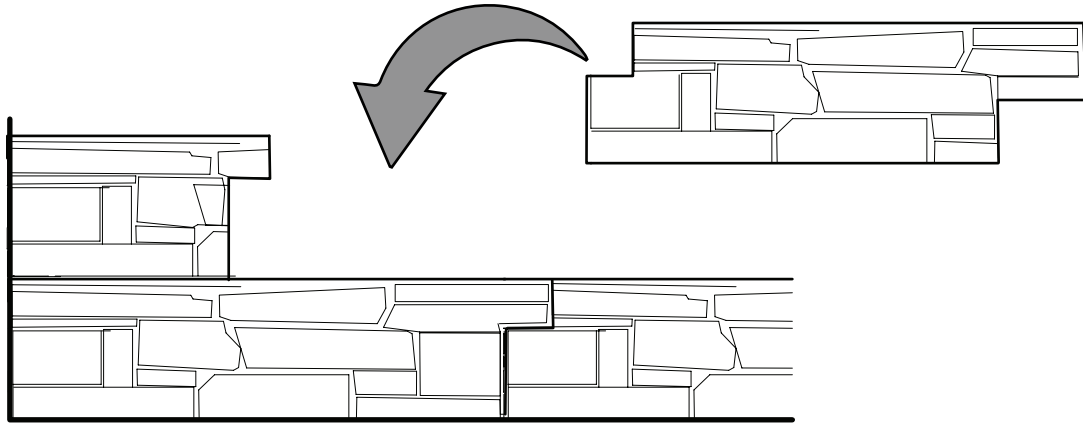

Next, start a new row with an offset so the seams do not line up. After cutting the stone, file the sides to avoid chipping and ensure a level and perfect fit. Use a level every time you install a new piece of stone. Be sure to interlock the stone pieces so they line up.

8

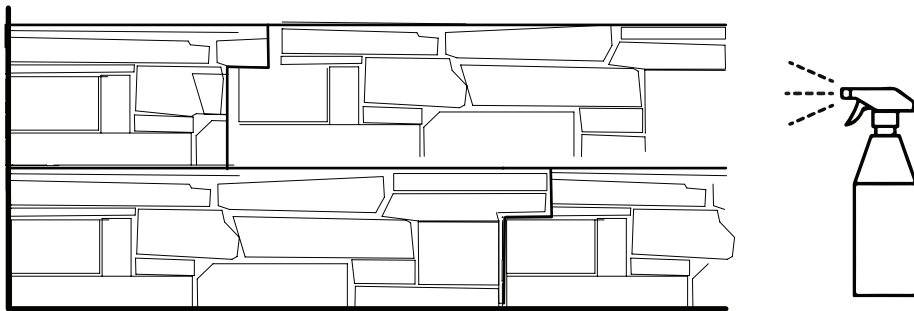

It is highly recommended you seal the stone with a quality water based sealer after installation.

Openings:

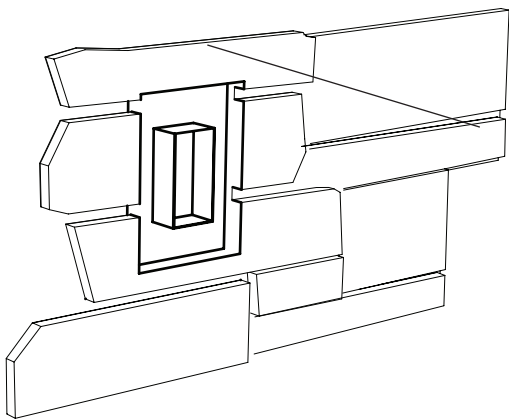

A/C
Receptacle

If you need to cut the stones, you can use a hand saw with a maximum 3 mm teeth. After cutting, remove the dust from the decorative stone.

Note: Illustrations not to scale

Maintenance and Contractual Warranty

Maintenance:

- Clean the stone with a duster or vacuum cleaner, making sure not to put the nozzle of the vacuum in direct contact with the stone.
- In case of deeply imprinted stain, seek the advice of a professional. Pay attention to non-specific cleaning products.
- After installation, protect the stone using a sealer to facilitate the maintenance.



Warning: Do not use a wire brush or wet sponge to clean the stone.

Limited Manufacturer Warranty:

Modulo Interior Products have a limited warranty of 50 years from the date of purchase. This warranty is subject to the following conditions:

- Strict compliance with the installation instructions.
- Showing the receipt or invoice.
- If your product is crushed it can be replaced at the place of purchase.

This warranty applies to the original purchaser and only for manufacturing defects. The stone are changed under these conditions, the cost of the disassembly and assembly are not included in this warranty.

The Purchaser will not be able to benefit from this warranty if:

- The decorative stones are installed on other surfaces than those intended (page 6) or on unstable, dirty, or dusty surfaces.
- The shifting of the surface is related to a structural problem of the building.
- There is a discoloring due to the contact with chemical contaminants, paint, dyes, oxidizing agents.
- There are cracks due to throwing of objects, high pressure action of air or water, or use of abrasive products.
- The product has been damaged during shipping.

Recommendation: Keep the receipt or invoice and the product references.